



Off-Gas System Controls

Actuation to loop tuning to closed loop control ·
Feed-forward & cascade strategies · Modelling



Dealing with Flow Variability in a Gas Train...

Is your off-gas system giving unacceptable levels of fugitive emissions? Are there multiple control elements, fans, dampers, coolers and etc., in your gas train that seem to be fighting each other, or not responding fast enough? Are you seeing large swings that force the plant operator to switch to MANUAL, or are you always in MANUAL? Does your plant have a large variability in gas flow that causes short periods of unwanted positive pressures – i.e. fugitives?

Traditional gas trains in sulphide based smelting processes rely on multiple control elements for draft control. For example, there could be an ID-fan on the off-gas of a Peirce-Smith converter, feeding a traditional acid plant which has an SO₂ blower. This system is a multi-variable problem since both the ID-fan and the SO₂ blower affect the pressure profile in the gas train, with disturbances from H₂O evaporative cooling, air dilution, intermittent blowing and etc.

We have experience with off-gas systems, and can equally work with your preferred control system integrator, or on-site resources, and facilitate the implementation of integrated controls for your gas train.

Improved control / operation and reduced fugitives are the end results.

Fan Actuation Old vs. New

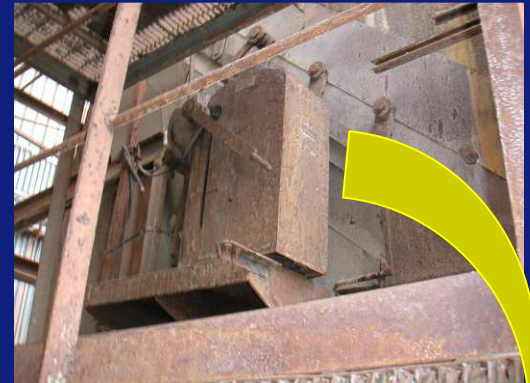

Example of a gas train with gas from two roasters and a converter aisle

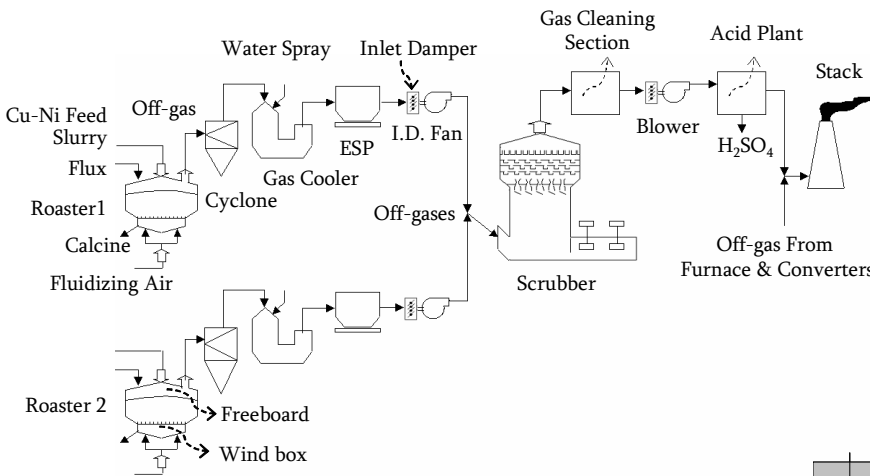

Schematic Diagram of Roaster Off-gas System

Single Roaster Control Loop Structure

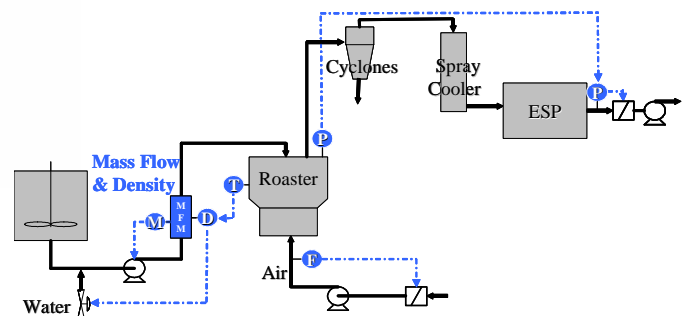

Contact Us...

www.myxps.ca

[Address] Process Control Group, XPS Centre, 6 Edison Road, Falconbridge, Ontario, P0M 1S0, CANADA
 [Phone] +1 (705) 699 3400 Ext. 3463 / 3442 / 3757 / 3427 [Fax] +1 (705) 699 3431
 [E-Mail] processcontrol@xstrataprocesssupport.ca or info@xstrataprocesssupport.ca

