



Controls Auditing

Control Systems Status Report · Evaluation of existing Control Strategies & Loop Tuning · Opportunity Identification · Development Road mapping



The Controls Audit...

Are you pumping resources into automation but still seeing no better plant control & performance?

Are you dealing with an older control system and unsure of how best to upgrade in order to meet your performance requirements?

Or do you simply want to get the most out of your valuable investment in plant automation?

Drawing on our experience in controlling Milling, Hydrometallurgical & Pyrometallurgical Processes, we will conduct an audit of your current controls. Benefits for you are:

- Get the most out of the controls already in place.
- Identify opportunities for improved performance.
- Recommend industry 'best practices' for your process.
- Establish 'roadmap' for upgrades / replacements.

We can also assist with implementation of any recommendations by drawing in the appropriate resources.

We can make it happen!

The Controls Audit forms the basis of the roadmap to Performance Excellence!



'Best Practice' strategies for equipment control

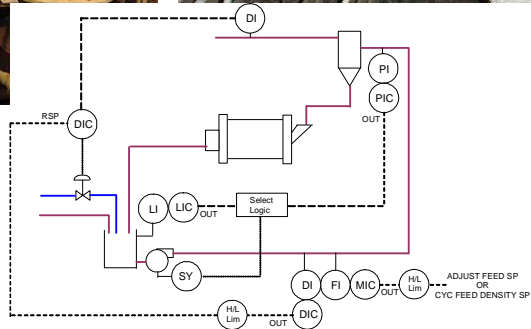

Past Clients & Activities...

- Collahuasi Mill (CMDIC & Xstrata Cu, Chile). Conducted a series of controls audits following commissioning. Collahuasi rated highest in AMIRA Controls Benchmarking Review (P893).
- Falcondo (Xstrata Ni) – Power Plant, Topping (Petroleum Refinery) Plant Audits.
- Altonorte (Xstrata Cu) – Control Review.
- CCR (Xstrata Cu) – Refinery audit. Basis for capital plan to upgrade & consolidate control systems.
- Horne Smelter (Xstrata Cu) – Acid plant Control Review.
- Peer Review Committee Participation on:
 - Nickel Rim South Mine (Xstrata Ni), Control System Selection, Communication Network Architecture;
 - Nikkelverk (Xstrata Ni), Control Room Centralization Project;
 - Kidd Creek (Xstrata Cu) 2.7Mtpy Mill Expansion.
- Clarabelle Mill (Vale INCO) – Control Review.

Define Appropriate Control System Architecture

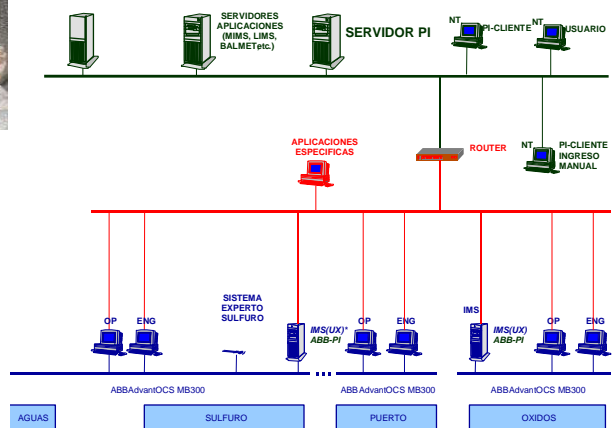

Contact Us...

www.myxps.ca

[Address] Process Control Group, XPS Centre, 6 Edison Road, Falconbridge, Ontario, P0M 1S0, CANADA
 [Phone] +1 (705) 699 3400 Ext. 3463 / 3442 / 3757 / 3427 |Fax] +1 (705) 699 3431
 [E-Mail] processcontrol@xstrataprocesssupport.ca or info@xstrataprocesssupport.ca

